

CIRCUITI IDRAULICI PER CALDAIE CON
SCAMBIATORE BITERMICO

MOD.

15AS40



Gruppo ritorno con flussostato sanitario ad effetto Hall

Return manifold with Hall effect sanitary flow sensor

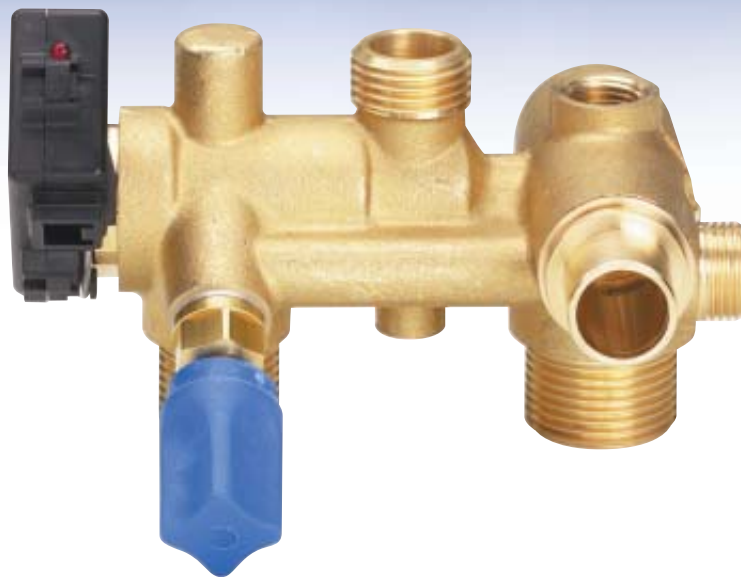

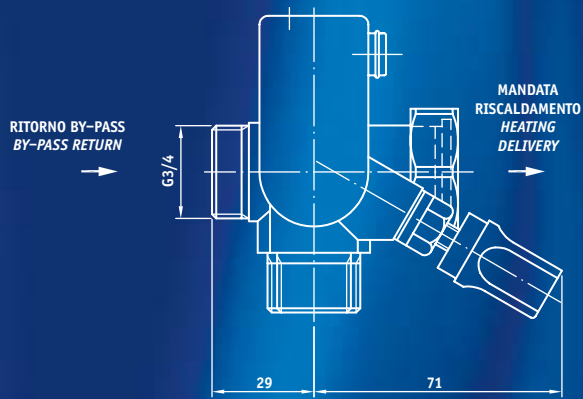
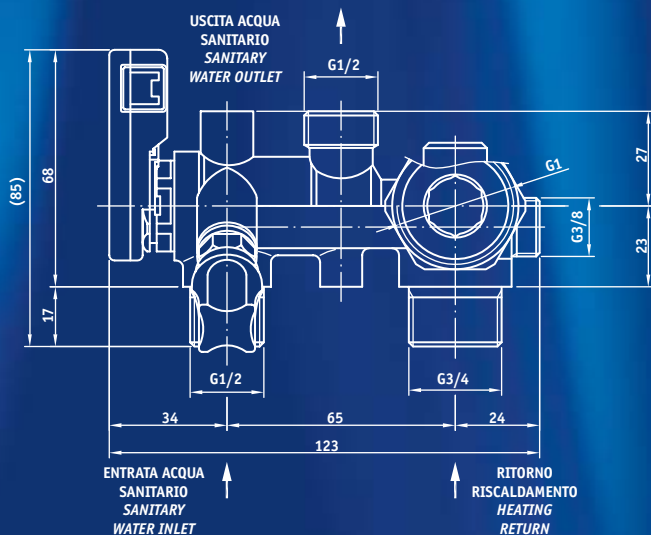

DATI TECNICI – TECHNICAL DATA

- Pressione minima acqua sanitaria 0.2bar
Minimum pressure sanitary water 0.2bar
- Portata minima di azionamento 2.5 l/min ±0.3
Switching flow rate 2.5 l/min ±0.3
- Portata massima di spegnimento 1.7 l/min
Releasing flow rate 1.7 l/min

- Rivelatore di flusso ad effetto Hall con filtro (regolatore di portata su richiesta)
Flow detector (Hall effect sensor) with filter (flow regulator on request)
- By-pass automatico
Automatic by-pass
- Raccordo vaso d'espansione
Expansion tank connection
- Raccordo pompa
Pump connection
- Rubinetto di riempimento impianto di riscaldamento
Manual filling tap

CIRCUITO SANITARIO
SANITARY CIRCUIT

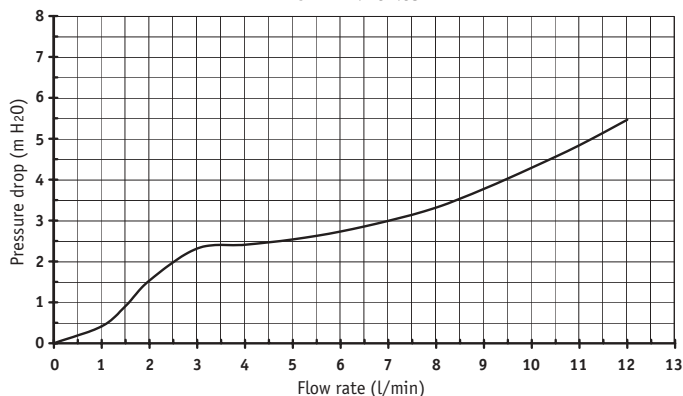

La curva rappresenta valori tipici / The curve represents typical performance.